

# INSIGHT SERIES FUEL GAUGE INSTALLATION GUIDE

24V & 48V MODELS

## THANK YOU FOR CHOOSING RELiON

Please read through this installation guide before installing your RELiON Fuel Gauge. Should you have any questions concerning installation or use, please contact us at [reliionbattery.com](http://reliionbattery.com)



### WHAT'S INCLUDED



**1x** RELiON  
Fuel Gauge



**1x** Fuel Gauge  
Cable Assembly  
(3 meter standard)  
(6 or 10 meter optional)



**1x** Mounting  
Bracket

The InSight Fuel gauge is a constantly backlit (no off switch) battery gauge that will show the state of charge (SOC) for up to 10 InSight Batteries connected in parallel. (InSight batteries should never be connected in series.)

## TECHNICAL SUPPORT

If you have technical questions about your RELiON Fuel Gauge, please contact the original place of purchase or RELiON Battery directly at [reliionbattery.com](http://reliionbattery.com)



## SETUP

1. Power down the device in which the fuel gauge will be installed. Power down the first InSight battery in the string by tapping the power button once and then depressing the button until both LEDs on the battery show solid red (approx. 6 seconds). Release button and the rest of the batteries in the string will also power off.
2. Begin by locating the Fuel Gauge Cable Assembly. Attach the red ring terminal to the positive battery post and then the black ring terminal to the negative battery post on the first or second InSight battery in the bank.
3. Insert the CANBUS plug attached to the wiring harness in the CANBUS IN port on the first InSight battery in the bank.
4. Route the other end of the cable through the mounting bracket to the fuel gauge display destination on the vehicle dashboard and insert the four-pin cable plug into the back of the gauge. Important note - be sure to route the cable through the mounting bracket on the back side of the dashboard. **Use zip ties to secure harness to vehicle to reduce strain on plugs!**
5. Insert the fuel gauge through the dashboard and seat in the mounting bracket. Rotate the mounting bracket until the fuel gauge is held firmly in place on the dashboard. Installation is now complete. The fuel gauge will display current state of charge and other messages communicated by the battery bank.

## FUEL GAUGE MESSAGES AND WARNINGS

The fuel gauge will display several messages throughout its operation cycle.

1. Upon startup the gauge will display the number of batteries detected. Make sure the number of batteries detected match the number of batteries in the bank. If the setup is not done correctly and the gauge does not read any batteries it will display the message "no comms".
2. During normal operation the fuel gauge will display the state of charge of the battery bank digitally as a percentage from 0-100%.
3. While the battery bank is above 20% state of charge the upper line of text will display the SOC while the second line displays the number of batteries and the remaining amp hours of the battery bank.
4. While the battery bank is below 20% state of charge the upper line of text will display the SOC while the second line will show "LOBATT" message.
5. While the battery bank is at or below 10% state of charge the upper line of text will display the SOC while the second line of text will flash "LOBATT" every 2 seconds.

## WIRING DIAGRAM

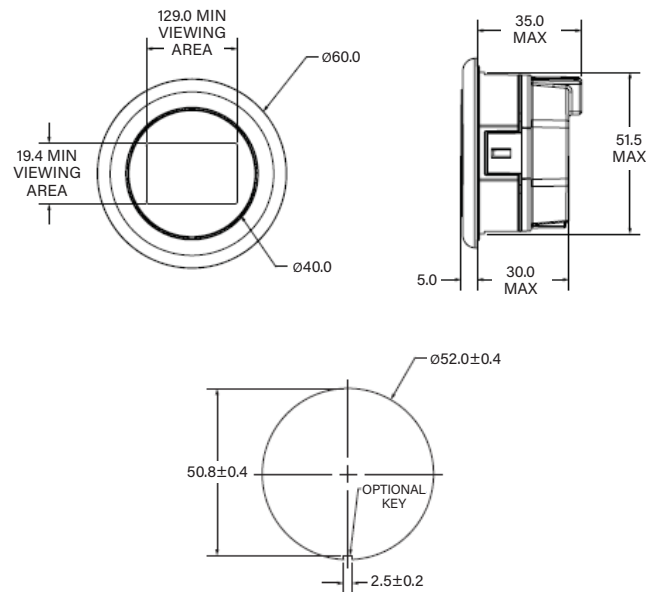
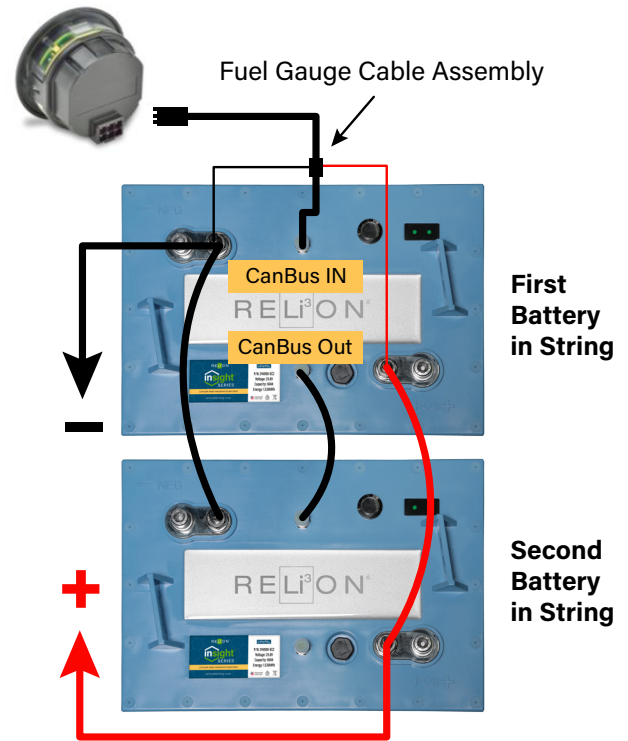

## SPECIFICATIONS

Operating Current	29 milliamps
Operating Temperature	14°F to 185°F (-10°C to 85°C)
Storage Temperatures	-40°F to 185°F (-40°C to 85°C)
Ingress Protection Rating	IP67

**Questions?** Contact RELiON Technical Support at (855) 931-2466